

Desuperheater

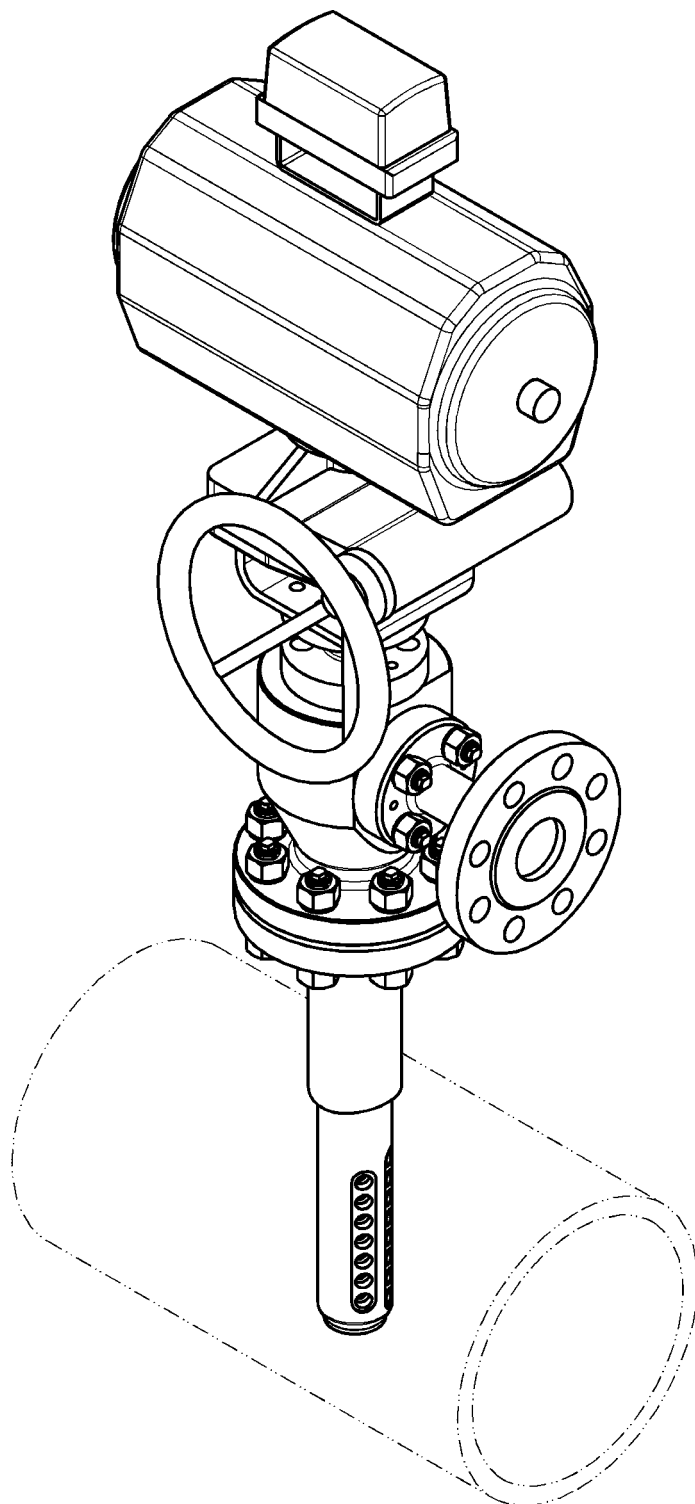

Contents

1 Identification3

1.1 ID plate of the fitting 3

2 General4

2.1 Use..... 4

2.2 Intended use 4

2.3 Warning symbols 5

3 Description6

3.1 Design of the desuperheater..... 6

3.2 Mode of operation of the desuperheater 7

3.3 Mode of operation of the temperature control 9

4 Assembly instructions11

4.1 General 11

4.2 Preparations for mounting..... 12

4.2.1 Mounting to connecting piece 12

4.2.2 Installation location 12

4.2.3 Installation in the line 13

4.2.4 Actuator..... 14

4.2.5 Insulation of the desuperheater 14

5 Startup15

5.1 Startup steps..... 15

5.2 During operation 16

5.3 Dismounting from the pipe line 16

5.4 Disassembly of the desuperheater 18

5.5 Inspection..... 18

5.6 Assembly 19

6 Tests19

6.1 Pressure test..... 19

6.2 Leak test 20

6.3 Functional test..... 20

7 Spare parts list.....21

| Created: | Checked/released: | Document: | Status/Rev.: |
|---------------------------------|---------------------------------|--------------------------------|--------------|
| on: 21.04.2004 by: K/Schüler | on: 14.07.2004 by: QS/Mathes | TB_Einspritzkuehler_Rev_03.doc | 03 |

1 IDENTIFICATION

1.1 ID PLATE OF THE FITTING

| | | | | | | | |
|--------------------|-----------|--------|-------|--------|--|-----|---|
| | Steam | | Water | | Opening angle | 10) | ° |
| DN / PN | 1) | | 5) | | Serial no. | 11) | |
| Operating temp. | 2) | °C | 6) | °C | Year of manufacture | 12) | |
| Operating pressure | 3) | bar(a) | 7) | bar(a) | Tag no. | 13) | |
| Material | 4) | | 8) | |  Tel.: 030 / 91204710 - Fax: 030 / 91204720 | | |
| II | KVS value | | 9) | | | | |

- 1) Nominal width and nominal pressure rating: steam connection
- 2) Max. operating temperature: steam
- 3) Max. operating pressure: steam
- 4) Material of fitting housing (steam connection)
- 5) Nominal width and nominal pressure rating: cooling water connection
- 6) Max. operating temperature: cooling water
- 7) Max. operating pressure: cooling water
- 8) Material of connection flange: cooling water
- 9) Flow characteristic (*K_{VS} value*) of the fitting
- 10) Opening angle of the fitting
- 11) Serial number of the fitting
- 12) Year of manufacture of the fitting
- 13) ID no. (*Tag no.*) of the fitting

| | | | |
|---------------------------------|---------------------------------|--------------------------------|--------------|
| Created: | Checked/released: | Document: | Status/Rev.: |
| on: 21.04.2004 by: K/Schüler | on: 14.07.2004 by: QS/Mathes | TB_Einspritzkuehler_Rev_03.doc | 03 |

2 GENERAL

2.1 USE

The desuperheater is used to control the temperature of steam and hot gases in power plants, chemical plants etc.

In this description, water is used as medium, for the sake of simplicity. The description analogously applies to other media.

The injected water is atomised to a micro-fine state by means of nozzles.

The integrated ball valve with the ball/seat ring system seals off the injection water.

To minimise wear, the ball is used as first throttle level, in special cases. This is noted in the valve data sheet, with the remark "*2-stage pressure reduction*".

The fitting is installed directly in the respective steam or process line.

2.2 INTENDED USE

The desuperheater is exclusively intended for regulating the temperature of steam and hot gases by means of injection of cooling water. Any other or additional use has to be agreed upon contractually.

This technical description and the operating data listed on the ID plate (see section 1.1 "ID plate of the fitting") have to be observed.

Adherence to local accident prevention and environmental protection regulations, as well as all customer specifications, is an integral part of intended use.

The safety information in the technical description has to be read prior to transporting, installing or repairing the desuperheater. The technical description has to be stored with care, so that its information is available at all times.

The technical description has to be accessible to the operating and service personnel at all times.

| Created: | Checked/released: | Document: | Status/Rev.: |
|---------------------------------|---------------------------------|--------------------------------|--------------|
| on: 21.04.2004 by: K/Schüler | on: 14.07.2004 by: QS/Mathes | TB_Einspritzkuehler_Rev_03.doc | 03 |

This technical description is intended for the service personnel of ARTES VALVE & SERVICE GmbH and the specialised personnel that have been trained by ARTES VALVE & SERVICE GmbH. If the repair tasks are performed by untrained personnel, the guarantee automatically becomes void.

2.3 WARNING SYMBOLS

Safety instructions and warnings are aimed at preventing danger to the life and health of users or maintenance personnel, and at preventing material damage. They are highlighted by means of the signal terms defined here. Furthermore they are designated by warning symbols (pictographs) whenever they occur. The meanings of the implemented signal terms are as follows:



DANGER!

Immediate danger to health and life or danger of extensive material damage in the event of non-adherence to the instructions.



CAUTION!

Dangerous situation
Instructions on avoiding damage



NOTE!

Help, suggestions or hints
regarding a procedure.

| Created: | Checked/released: | Document: | Status/Rev.: |
|---------------------------------|---------------------------------|--------------------------------|--------------|
| on: 21.04.2004 by: K/Schüler | on: 14.07.2004 by: QS/Mathes | TB_Einspritzkuehler_Rev_03.doc | 03 |

3 DESCRIPTION

3.1 DESIGN OF THE DESUPERHEATER

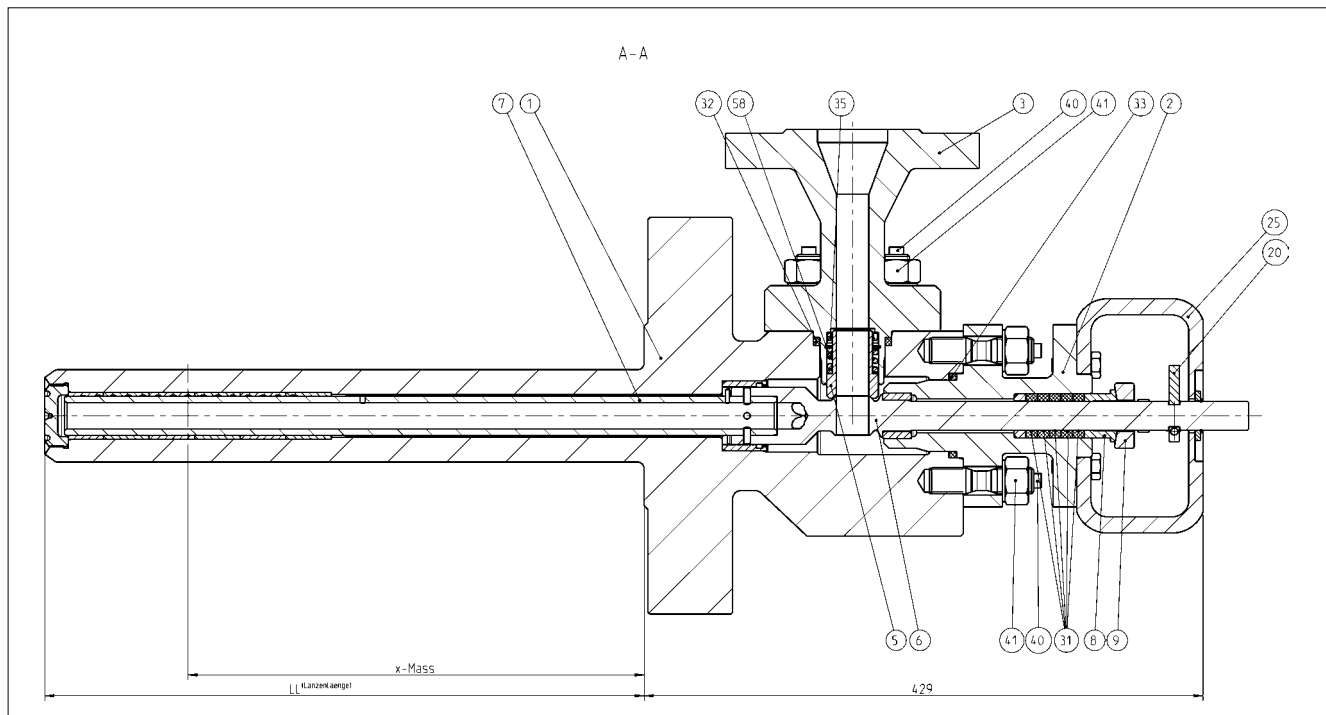

Fig. 3.1 Sectional view of the desuperheater

- | | | |
|--|--------------------------------|---------------------------------|
| <i>Pos. 1 - Housing</i> | <i>Pos. 7 - Nozzle stem</i> | <i>Pos. 31 - Packing</i> |
| <i>Pos. 2 - Packing housing</i> | <i>Pos. 8 - Pressure piece</i> | <i>Pos. 32 & 33 - Seals</i> |
| <i>Pos. 3 - Cooling water connection</i> | <i>Pos. 9 - Gland follower</i> | <i>Pos. 35 - SR seal</i> |
| <i>Pos. 5 - Seat ring</i> | <i>Pos. 20 - Indicator</i> | <i>Pos. 40 - Stud bolt</i> |
| <i>Pos. 6 - Ball stem</i> | <i>Pos. 25 - Frame</i> | <i>Pos. 41 - Hexagon nut</i> |

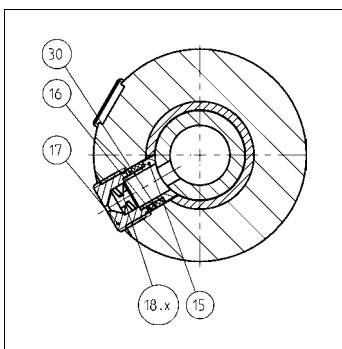

Fig. 3.2 Sectional view of the nozzle

- | |
|----------------------------------|
| <i>Pos. 15 - Bushing</i> |
| <i>Pos. 16 - Adapter ring</i> |
| <i>Pos. 17 - Nozzle</i> |
| <i>Pos. 18.x - Nozzle insert</i> |
| <i>Pos. 30 - Seal</i> |

| | | | |
|---|--|---|--------------------|
| Created: on: 21.04.2004 by: K/Schüler | Checked/released: on: 14.07.2004 by: QS/Mathes | Document: TB_Einspritzkuehler_Rev_03.doc | Status/Rev.: 03 |
|---|--|---|--------------------|

3.2 MODE OF OPERATION OF THE DESUPERHEATER

The temperature of steam and hot gases is controlled by regulating the cooling water injected into a steam or hot gas current.

With the desuperheater, it is possible to precisely control the injection quantity in accordance with the characteristic curve, by means of a special, individual nozzle control system that has been adapted to the operating conditions.

The implementation of a nozzle system with integrated swirl inserts enables constant, very fine atomisation of the cooling water in all load ranges. Water is supplied to the individual nozzles through boreholes in such a way that the characteristic curve of the valve has no steps.

The order in which the nozzles open has been determined by the design and construction. The nozzles located in the middle of the desuperheater are the first to inject cooling water.

The desuperheater has to be integrated into the pipe in such a way that the nozzle that opens first is located in the middle of the pipe. This ensures that the water is injected into the area with the highest flow speed, even when the flow rate is low. The distance between the first nozzle and the pipe wall is the largest. This largely prevents thermoshock at the pressurised steam line or insufficient performance in the case of low steam flow rates.

| Created: | Checked/released: | Document: | Status/Rev.: |
|---------------------------------|---------------------------------|--------------------------------|--------------|
| on: 21.04.2004 by: K/Schüler | on: 14.07.2004 by: QS/Mathes | TB_Einspritzkuehler_Rev_03.doc | 03 |

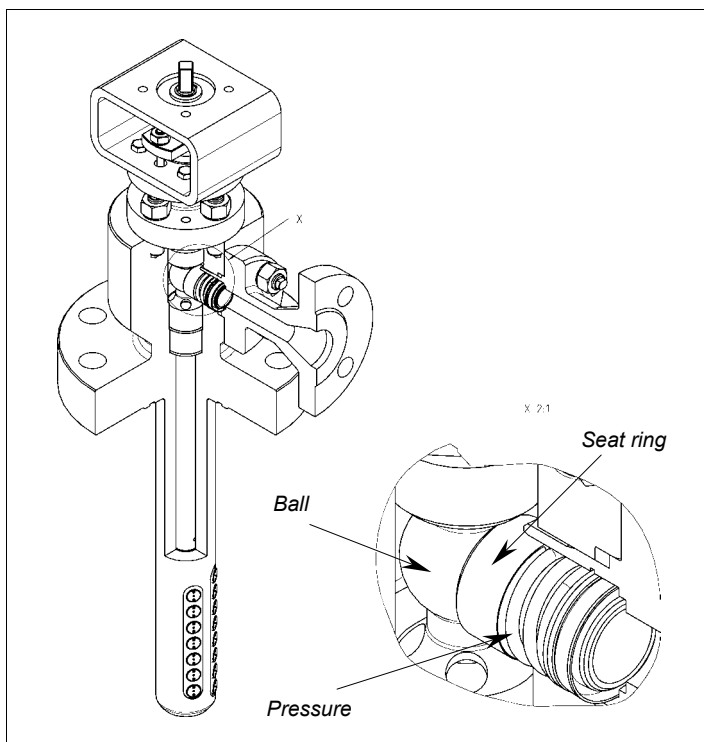

Fig. 3.3 Integrated ball valve - ball/seat ring system

The ball valve that is integrated into the desuperheater blocks off the cooling water.

The sealing requirements for this blocking valve are specified in the contract. By default, the fitting complies with the requirements for control fittings as set out in VDI/VDE 2174 (the leakage flow, calculated for uniform conditions, is less than 0.05% of the K_{VS} value). Compliance with DIN/EN 12266-1 has to be specially arranged.

The ball/seat ring system is a pure metal seal and therefore can seal tightly for a long duration of time.

When the differential pressure between the steam or hot gas and the cooling water is low, the entire differential pressure is applied at the nozzle systems, due to the very low loss of power within the desuperheater.

The differential pressure between the steam or hot gas and the cooling water should be at least 5 bar. If the differential pressure increases to values higher than 30 bar, increased wear at the nozzles should be expected.

The nozzle wear can be minimised by using multi-stage pressure reduction. Here the ball/seat ring system is used as first regulated throttle stage. The contour integrated into the ball and the control characteristics achieved by means of the nozzles form a unit.



To minimise the nozzle wear, it is possible to use nozzles made of *stellite*. Care must be taken that the quality of the injected water does not cause corrosion of the *stellite*. In power plants that apply the so-called “combi-mode”, it is not permissible to use *stellite*.

| Created: | Checked/released: | Document: | Status/Rev.: |
|---------------------------------|---------------------------------|--------------------------------|--------------|
| on: 21.04.2004 by: K/Schüler | on: 14.07.2004 by: QS/Mathes | TB_Einspritzkuehler_Rev_03.doc | 03 |

3.3 MODE OF OPERATION OF THE TEMPERATURE CONTROL

If no special agreements have been made, the control system of the desuperheater and actuator unit is not included in the scope of supply provided by ARTES VALVE & SERVICE GmbH.

The subsequent text describes a typical temperature control. This is only an example and is not binding for specific applications:

Three temperature sensors, located downstream of the desuperheater, measure the ACTUAL steam temperature and send the value to the control system. If the SETPOINT and ACTUAL temperature value deviate, the actuator of the desuperheater is activated.

Usually a 4 - 20 mA control signal is used. The fitting is closed at 4 mA.

The actuator sets the desuperheater to the required position, in accordance with the change in the control signal. The stem rotation causes the nozzles to be switched on and off and the appropriate control characteristic is applied to control the injection quantity in accordance with the requirements of the valve's characteristic curve. This process continues until the SETPOINT and ACTUAL value match.

| Created: | Checked/released: | Document: | Status/Rev.: |
|---------------------------------|---------------------------------|--------------------------------|--------------|
| on: 21.04.2004 by: K/Schüler | on: 14.07.2004 by: QS/Mathes | TB_Einspritzkuehler_Rev_03.doc | 03 |

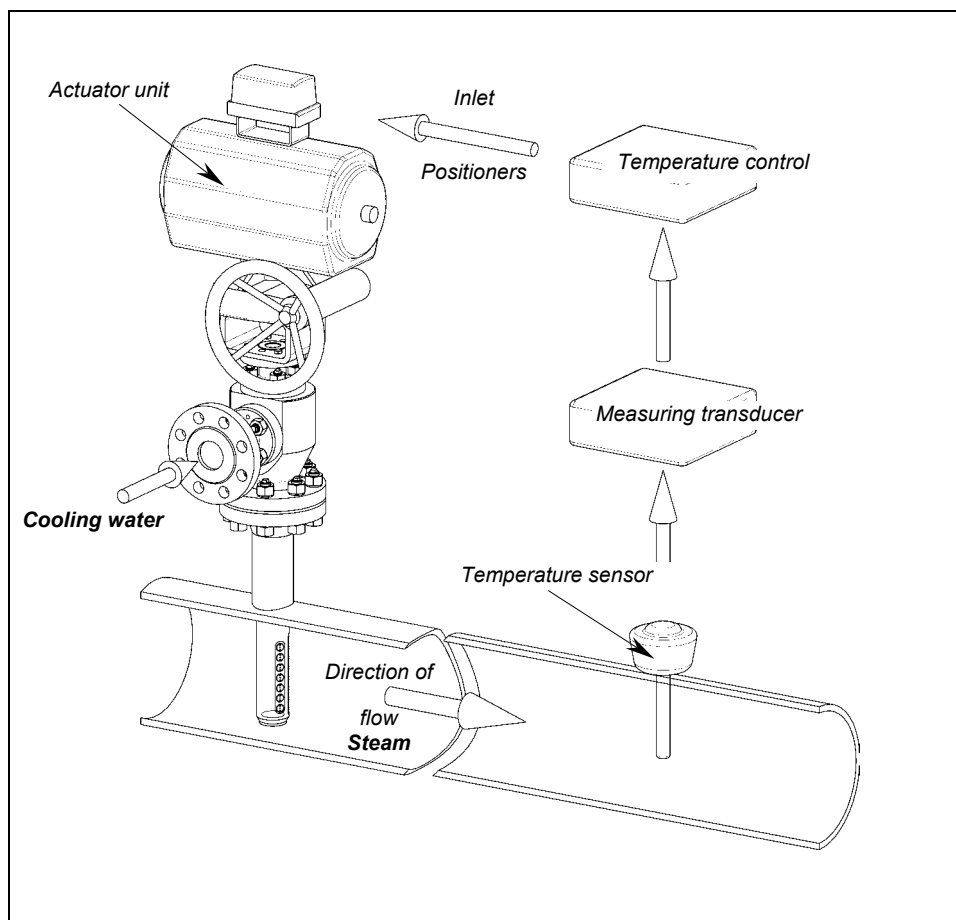

Fig. 3.4 Schematic diagram - Mode of operation of the temperature control

Normally feedforward control is achieved through input of valve settings for the steam flow control valves or “pre- and post-superheater” temperatures.

If no special agreements have been made, ARTES VALVE & SERVICE GmbH does not provide any warranty for the correctness of the control system (because it is not part of the scope of delivery).

Electric, pneumatic or hydraulic variable speed drives can be used as actuator for the desuperheater. The actuator and desuperheater are subjected to a functionality test prior to shipment.



We recommend that filtering screens are installed in the cooling water line to prevent contamination of the desuperheater and to increase the maintenance intervals.

ARTES VALVE & SERVICE GmbH does not accept any liability for damage to the fitting caused by foreign objects.

| | | | |
|---|--|---|--------------------|
| Created: on: 21.04.2004 by: K/Schüler | Checked/released: on: 14.07.2004 by: QS/Mathes | Document: TB_Einspritzkuehler_Rev_03.doc | Status/Rev.: 03 |
|---|--|---|--------------------|

4 ASSEMBLY INSTRUCTIONS



Non-adherence to the following assembly instructions voids the warranty claims.

4.1 GENERAL



Desuperheater

- ⇒ The desuperheater may only be installed by the service personnel of ARTES VALVE & SERVICE GmbH or by trained specialists.
- ⇒ Care must be taken that no piping forces can act on the desuperheater.
- ⇒ The flange seals at the steam flange and at the cooling water connection have to be selected in accordance with the operating data. The manufacturer's specifications have to be observed.



Actuator

- ⇒ The instructions in the technical description of the actuator have to be observed. If it is not included as appendix, it has to be ordered.
- ⇒ The factory settings of the actuator may not be modified.
- ⇒ The max. permissible ambient temperature for the actuator may not be exceeded (observe the operating instructions of the actuator!).

| Created: | Checked/released: | Document: | Status/Rev.: |
|---------------------------------|---------------------------------|--------------------------------|--------------|
| on: 21.04.2004 by: K/Schüler | on: 14.07.2004 by: QS/Mathes | TB_Einspritzkuehler_Rev_03.doc | 03 |

4.2 PREPARATIONS FOR MOUNTING

4.2.1 *Mounting to connecting piece*



Prior to mounting the desuperheater, the following points have to be checked and documented, because the lance of the desuperheater must not touch other components:

1. ACTUAL bore diameter of the connecting piece of the steam or hot gas line
2. ACTUAL hole circle diameter of the boreholes in the connecting piece of the steam or hot gas line
3. Distance from sealing surface of the connecting piece to the centre of the steam or hot gas line
4. Form and position of the connecting piece
5. Impermissible weld root penetration has to be eliminated.
6. The lance may not make contact with the steam line or thermoshock pipe on the opposite site of the steam connecting piece. Thermal expansion during operation has to be taken into account. If necessary, a borehole has to be made in the thermoshock pipe opposite.

4.2.2 *Installation location*

1. Choose an installation location where the desuperheater is always accessible.
2. If the fitting and the actuator together weigh more than *30 kg*, a possibility to attach a chain hoist has to be provided for mounting the fitting in the steam line.
3. The actuator has to be easily accessible for adjustments.
4. There has to be a straight pipe of at least **5 x d_{CL}** upstream of the cooling water flange (d_{CL} - diameter of cooling water line).
5. There has to be a straight steam pipe of **5 x d_{SL}** upstream of the desuperheater (d_{SL} - diameter of steam line).

| Created: | Checked/released: | Document: | Status/Rev.: |
|---------------------------------|---------------------------------|--------------------------------|--------------|
| on: 21.04.2004 by: K/Schüler | on: 14.07.2004 by: QS/Mathes | TB_Einspritzkuehler_Rev_03.doc | 03 |



The specifications for the straight outflow section downstream of the fitting and the distance to the temperature sensors are listed in the data sheet of the valve. These minimum distances have to be observed.

4.2.3 Installation in the line



The following points have to be taken into account when installing the desuperheater:

1. No forces and torques from the supply line of the injection medium may act on the desuperheater.
2. Care must be taken that no contaminations from the line can damage the desuperheater. The line section between the filtering screen and the desuperheater has to be checked. In new plants, it is recommended to design appropriately shaped weld seams.
3. When the fitting is mounted to the connecting piece, ensure that the axis of the desuperheater is aligned with the axis of the connecting piece. There has to be an even annular gap of at least *2.0 mm* between the connecting piece and the lance.
4. The screw connections at the steam and cooling water flange have to be tightened crosswise and evenly, with the torque required for the selected seal and the respective application.



The water is injected through the nozzles, in the direction of flow of the steam!

| Created: | Checked/released: | Document: | Status/Rev.: |
|---------------------------------|---------------------------------|--------------------------------|--------------|
| on: 21.04.2004 by: K/Schüler | on: 14.07.2004 by: QS/Mathes | TB_Einspritzkuehler_Rev_03.doc | 03 |

4.2.4 Actuator



The desuperheater is supplied with a mounted actuator. If it is required to dismount the fitting and actuator, the following instructions have to be observed. The technical description supplied by the manufacturer of the actuator also has to be observed.

1. The desuperheater has to be "OPENED" or "CLOSED" to a defined position by means of the actuator. In this position, the signal feedback of 4 - 20 mA (normally) and the final position switch have been preset at the factory. **This final position has to be used for re-mounting the fitting and actuator!** Mark the position (for example through a *coloured marking*).
2. During dismounting and mounting, take care that no forces and torques affect the spindle of the desuperheater. Otherwise damage to the ball of the ball stem (*pos. 6*), the seat ring (*pos. 5*) and the nozzle system (*pos. 15, 16, 17, 18.x & 30*) cannot be excluded. During the mounting procedure, the screws have to be tightened crosswise at the required torque.



Never loosen the screw connection and turn the actuator on the desuperheater. The nozzle stem (*pos. 7*) will also be turned, with the result that the nozzles will not be activated correctly any more!

4.2.5 Insulation of the desuperheater



It is recommended not to enclose the steam flange and the cooling water flange in insulation. This makes it easier to detect leaks and no damage to the insulation, caused by leaks, occurs.

However, due to the high temperatures of the components, care must be taken that the components cannot be touched.

The insulation has to be fitted in such a way that the max. ambient temperatures for the actuator, as prescribed by the manufacturer, are not exceeded.

| Created: | Checked/released: | Document: | Status/Rev.: |
|---------------------------------|---------------------------------|--------------------------------|--------------|
| on: 21.04.2004 by: K/Schüler | on: 14.07.2004 by: QS/Mathes | TB_Einspritzkuehler_Rev_03.doc | 03 |



The sealing of the injection water line at the seat ring is suitable for a max. temperature of 300 °C. It has to be ensured that no heat accumulation can occur at the housing due to the housing being insulated or due to a installation location that does not offer sufficient air circulation.

5 STARTUP



The operating conditions stipulated in the purchasing contract have to be observed. Else the warranty becomes void.

The ID plate of the desuperheater lists the design data for the steam and water side. These values may not be exceeded.

5.1 STARTUP STEPS

1. All screw connections have to be inspected while they are cold.
2. The actuator has to be run through its entire range while it is cold. If there is stiffness of movement, the packing has to be loosened.
The feedback signal and the final positions, as well as the intermediate positions (if applicable) have to be inspected and calibrated. The manufacturer's specifications and the operating manual of the actuator have to be observed.
3. The injection water line has to be vented at the highest point, else water hammer can damage the fitting. If the desuperheater itself is located at the highest point in the injection water line, the line can be vented into the steam line, via the fitting. To do so, the desuperheater has to be **completely open**.
4. When the operating temperature has been reached, all screw connections have to be inspected again and retightened if necessary.



Check that the packing has been tightened to the correct torque. At operating temperature it is possible that the packing blocks the spindle. This is entirely normal. If this occurs, loosen the packing until the spindle is not blocked any more. Here, as always, care must be taken to ensure tightness against leaks.

| Created: | Checked/released: | Document: | Status/Rev.: |
|---------------------------------|---------------------------------|--------------------------------|--------------|
| on: 21.04.2004 by: K/Schüler | on: 14.07.2004 by: QS/Mathes | TB_Einspritzkuehler_Rev_03.doc | 03 |

5.2 DURING OPERATION

During operation, the desuperheater has to be checked for leaks to the outside.

The frequency of the inspections depends on the plant requirements, however they should be performed at least every six months.

The revision intervals for the desuperheater primarily depend on the differential pressure between the water and the steam, and the water quality. These criteria are responsible for wear to the components. Normally servicing tasks are performed after 16,000 operating hours.

It is recommended that the desuperheater is always serviced after 24,000 operating hours.

Damage to the pressurised components is almost entirely impossible when proper operation is adhered to.



Only ARTES VALVE & SERVICE GmbH personnel or trained specialists may perform the servicing tasks, else the warranty becomes void.

5.3 DISMOUNTING FROM THE PIPE LINE

1. Switch off the section of the plant. The regulations applying to the plant have to be observed.
2. Obtain written confirmation that the plant is not pressurised (release).
3. Check the on-site temperature. The temperature of the components have to be lower than the temperature permitted by the relevant authorities.
4. Carefully loosen the flange on the water and steam side.
5. Remove from the steam line.



The actuator may not be used to lift the entire unit. If required, dismantle the actuator and fitting separately (also see section 4.2.4 “Actuator”)

| Created: | Checked/released: | Document: | Status/Rev.: |
|---------------------------------|---------------------------------|--------------------------------|--------------|
| on: 21.04.2004 by: K/Schüler | on: 14.07.2004 by: QS/Mathes | TB_Einspritzkuehler_Rev_03.doc | 03 |



The packing housing can be used to lift the desuperheater by means of a strap.

- 6. A Euro pallet can be used for transport purposes. Caution! Secure properly.

| Created: | Checked/released: | Document: | Status/Rev.: |
|---------------------------------|---------------------------------|--------------------------------|--------------|
| on: 21.04.2004 by: K/Schüler | on: 14.07.2004 by: QS/Mathes | TB_Einspritzkuehler_Rev_03.doc | 03 |

5.4 DISASSEMBLY OF THE DESUPERHEATER

All flange connections have to be marked prior to loosening them and have to be refit at the same positions later.

1. Dismount the actuator.
2. Dismount the cooling water connection.
3. Dismount the nozzles. Complete a nozzle protocol prior to disassembly (see Appendix)
4. Remove the unit formed by the frame (*pos. 25*), the packing housing (*pos. 2*) and the ball stem (*pos. 6*).
5. Dismantle into individual parts.
6. Clean all parts.

5.5 INSPECTION

All components have to be subjected to a visual inspection. The degree of wear incurred on components that are subject to wear has to be determined.

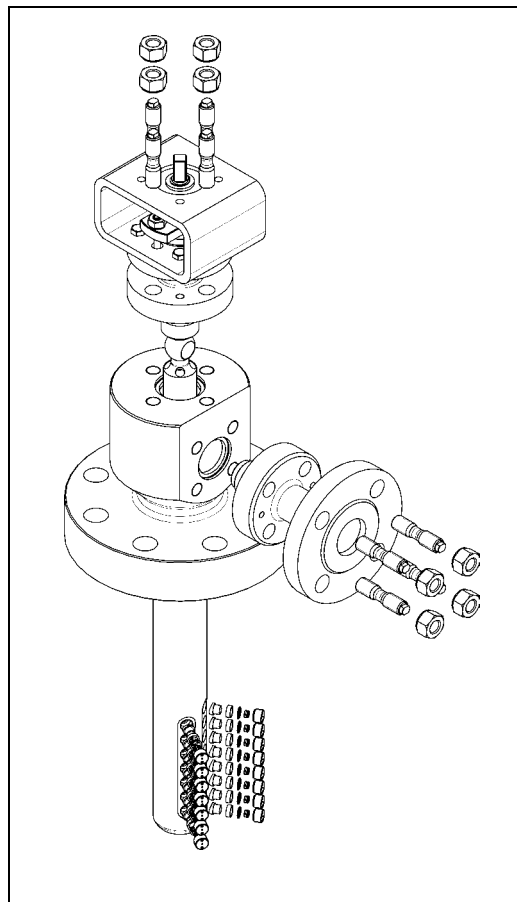

Fig. 5.1 Disassembly



If it cannot be guaranteed that the components will have high enough quality until the next service stop, the components have to be exchanged.

Use only original spare parts.

| Created: | Checked/released: | Document: | Status/Rev.: |
|---------------------------------|---------------------------------|--------------------------------|--------------|
| on: 21.04.2004 by: K/Schüler | on: 14.07.2004 by: QS/Mathes | TB_Einspritzkuehler_Rev_03.doc | 03 |

5.6 ASSEMBLY

Prior to assembly, the contact pattern of the seat ring (*pos. 5*) on the ball of the ball stem (*pos. 6*) has to be inspected. Re grind with diamond paste (*800 grit*) if required.

All bushings (*pos. 15*) have to be ground in on the nozzle stem (*pos. 7*) at the position where the assembly will take place later (*800 grit*).

For assembly, reverse the steps described at 5.4 "Disassembling the desuperheater".

When assembling the nozzle system (*pos. 15, 16, 17, 18.x & 30*), make sure that the entire surface of the bushings (*pos. 15*) make contact with the nozzle stem (*pos. 7*). Canting can cause grooves on the nozzle stem. This can lead to leaks.

When the nozzles are screwed in (*pos. 17*), the pure graphite ring (*pos. 30*) has to be pressed forward; subsequently the nozzle (*pos. 17*) has to be loosened again by a quarter turn. The torque of the ball stem (*pos. 6*) and nozzle stem (*pos. 7*) have to be checked during assembly of each nozzle (*pos. 17*) (*stiffness*).

6 TESTS

6.1 PRESSURE TEST

The desuperheater has been subjected to a pressure test when it was new. The test pressure can be found in the documentation.

After the service tasks have been completed, the pressure test has to be repeated.



The steam flange of the housing is not subjected to a pressure test. The pressure test for the steam flange is done in the plant.

| Created: | Checked/released: | Document: | Status/Rev.: |
|---------------------------------|---------------------------------|--------------------------------|--------------|
| on: 21.04.2004 by: K/Schüler | on: 14.07.2004 by: QS/Mathes | TB_Einspritzkuehler_Rev_03.doc | 03 |

6.2 LEAK TEST

It is necessary to differentiate between two leak tests:

- ⇒ Leak test for the ball/seat ring system
- ⇒ Leak test for the nozzles

The leak tightness of the fitting, in other words the ball/seat ring system, is done with water at a test pressure of *6 bar*.

Among themselves, the nozzles have to seal tightly, so that no undesirable drops of water resulting from untight nozzles can lead to thermoshock in the steam line during operation with partial load.

The nozzle tightness is checked with water, at a pressure of *6 bar*. To do so, the desuperheater is opened slowly. The nozzles then have to consecutively open and close in the prescribed order. If water escapes at the thread of the nozzle, the nozzle has to be tightened slightly. The ease of movement of the stem system (ball stem (*pos. 6*) & nozzle stem (*pos. 7*)) may not be influenced. If necessary, regrind the bushing (*pos. 15*).

After the leak test has been completed, secure the nozzles against being turned to the wrong position. This is done by means of two punches.

6.3 FUNCTIONAL TEST

The functionality of the desuperheater is tested together with the actuator. The torque, the feedback signal and the displacement switches are configured.

The technical description supplied by the manufacturer of the actuator has to be observed.

The technical description of the actuator can be found in the appendix.

| Created: | Checked/released: | Document: | Status/Rev.: |
|---------------------------------|---------------------------------|--------------------------------|--------------|
| on: 21.04.2004 by: K/Schüler | on: 14.07.2004 by: QS/Mathes | TB_Einspritzkuehler_Rev_03.doc | 03 |

7 SPARE PARTS LIST

The listed spare parts are recommended by the manufacturer.

| Pos. | Designation | Material |
|-------------|--------------------|---------------------------------|
| 5 | Seat ring | 1.4122 |
| 6 | Ball stem | 1.4122 |
| 7 | Nozzle stem | 1.4301 / 1.4057 |
| 8 | Pressure piece | 1.4541 |
| 9 | Gland follower | See parts list in documentation |
| 15 | Bushing | 1.4122 |
| 16 | Adapter ring | 1.4122 |
| 17 | Nozzle | 1.4122 / Stellite |
| 18.x | Nozzle insert | 1.4541 |
| | Seal assembly | |

| | | | |
|---------------------------------|---------------------------------|--------------------------------|--------------|
| Created: | Checked/released: | Document: | Status/Rev.: |
| on: 21.04.2004 by: K/Schüler | on: 14.07.2004 by: QS/Mathes | TB_Einspritzkuehler_Rev_03.doc | 03 |